

Operating and assembly instructions GISKB crane systems

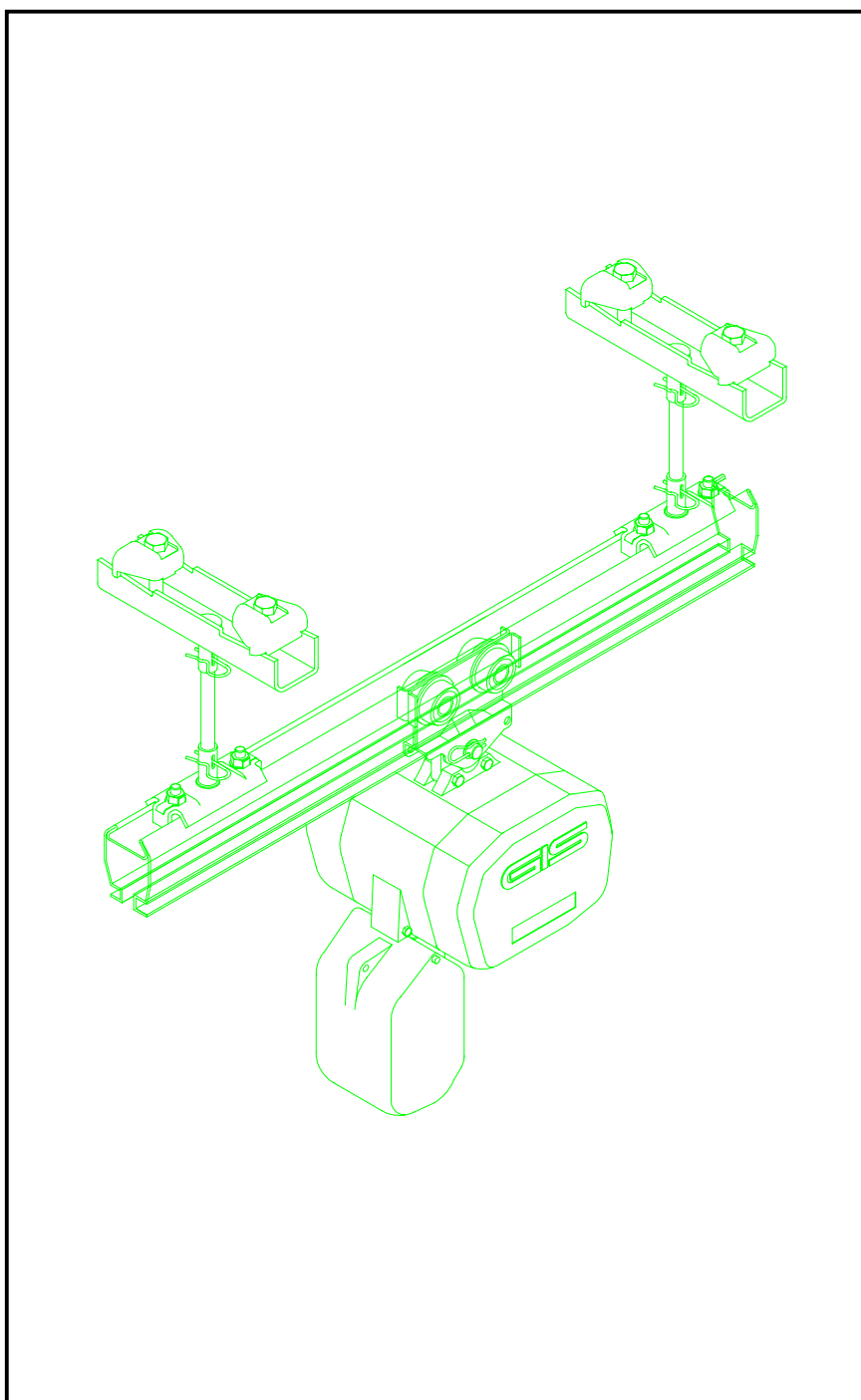
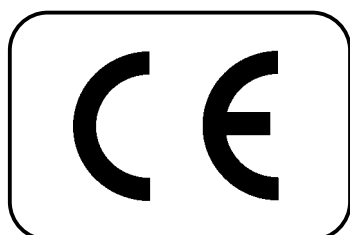

GISKB I
GISKB II

TABLE OF CONTENTS

	Page		Page
0		General directions	3
0.1	3	General safety directions	
0.1.1	3	Safety and hazard precautions	
0.2	3	General safety specifications and procedures	
0.2.1	3	Warning colour/Marking/Danger signs	
0.3	3	Special safety directions	
0.4	3	Notes on hazard protection	
0.4.1	3	Hazards caused by mechanical influences	
0.4.2	4	Hazards caused by electrical energy/power supply	
0.5	4	Technical status	
0.5.1	4	Technical datas	
0.5.2	4	Recurrent checks	
0.6	4	Operational parameters	
0.6.1	4	Directions for the use of the instruction manual	
1		Assembly instructions	4
1.1	4	Introduction	
1.1.1	5	Assembly requisites	
1.2	5	Assembly of crane track or overhead monorail	
1.2.1	5	Ceiling structure	
1.2.2	5	Suspension pendulating short	
1.2.3	5	Suspension pendulating from rod	
1.2.4	5	Bracing pendulating from rod	
1.2.5	5	Rigid suspension	
1.2.6	5	Joining profiles	
1.3		Assembly of the crane bridge	5
1.3.1		Single crane bridge	5
1.3.2		Double crane bridge	6
1.3.3		Profile reinforcement	6
1.3.4		Combination of trolleys	6
1.4		Electrical equipment	6
1.4.1		Trailing cable in the profile	6
1.4.2		Trailing cable on C-rail	6
1.4.3		Conductor line	6
2		Start-up	6
2.1		Checks following installation and adjustment	6
2.1.1		Check the fuses	6
2.1.2		Check on electric connections	6
2.1.3		Functional checks	6
2.1.4		Operation	6
3		Service and maintenance	6
3.1		General regulations for service- and maintenance work	6
3.2		Maintenance	7
3.2.1		Maintenance summary	7
3.3		Service	7
3.3.1		Service summary	7
3.4		Ordering of spare parts	7

Spare parts / Ordering of spare parts

The correct order numbers for the original spare parts are to be taken from the documentation. Please ensure that you have the following data on your crane system type on hand. Thereby a quick and correct supply of the parts required will be effected.

Crane system type :

Year of manufacture :

Load capacity :

Original spare parts for the GISKB crane systems can be acquired from the following addresses:

1. Manufacturer

GIS AG
 Hebe- und Fördertechnik
 Luzernerstrasse 50
 CH-6247 Schötz

2. Agent

.....

0 General directions

0.1 General safety directions

0.1.1 Safety and hazard precautions

The following symbols and terms are used in this instruction manual for safety and hazard instructions:



DANGER !

The non-compliance either in part or full of work and operational directions marked with this symbol can result in serious personal injury or even death. Danger notices must be **strictly** complied with.



CAUTION !

The non-compliance either in part or full of work and operational directions marked with this symbol can result in major machinery, property or material damage. Cautionary notices must be **strictly** adhered to.



NOTE

Effective and simple operation is the result of following the directions denoted under this symbol. "Note" directions make light work.

0.2 General safety specifications and procedures

The operating instructions for the crane system must be kept within the operating area of the installation.

Furthermore, supplementary to the operating instructions, the statutory regulations governing general accident prevention and environment protection are to be enforced.

The operator must observe the following standards and regulations concerning construction, construction inspection and operation of crane systems:

EC-Regulations for machines amended by	89/392/EWG 91/368/EWG 93/68/EWG
EC-Low voltage regulation	73/23/EWG
EN 292	Safety of machines
IEC 34-1	Circulatory electric machines
IEC 34-5	IP protections
IEC 364	Electric installations
IEC 947-5-1	Low voltage control gears
DIN 15018	Cranes, principles for steel structures
DIN 15019	Cranes, stability accident prevention regulations

Operating and service personnel must have read and understood the operating instructions, in particular the safety instructions, before commencing work. Protection gear for operating and service personnel must be made available and worn at all times.

The operator or its designate is responsible for the safety and hazard awareness of the operating personnel and is responsible for the supervision thereof.

0.2.1 Warning colour / Marking / Danger signs

- Load plate figure 0-1

0.3 Special safety directions

Transport and assembly:

- single parts and large components are to be carefully affixed to suitable and technically acceptable hoisting apparatus / load lifting members

Connection:

- The connection work is only to be effected by personnel specifically designated and trained for the job

Start-up/operation:

- Before initial startup, as well as daily startup carry out a visual check and effect the predefined user-checks routine
 - Do not omit any serious safety procedure
 - Only put the crane system into operation when the available protection and safety apparatus is fully functional
 - Damage to the crane system and changes in its operational characteristics must be reported immediately to the person responsible
 - After use, or when in a non-operational mode, the crane system should be secured against unauthorised and unwarranted use
 - Transport of persons is not allowed
 - Moving loads above persons is not allowed
 - Persons are not allowed to remain below moving loads
 - Moving of overloads is not permitted
 - Do not pull the control cable
 - Always monitor and control the load
- See also adequate application (chapter 0.6)

Cleaning/service/repair/maintenance/refitting:

- For assembly work above body height, the necessary working platforms or ladders are to be made available
- Do not use machine parts for this purpose
- Check the electrical cable for chaff marks and damage
- For safety and environmental protection, trap and dispose of fuel or other agents used
- Safety apparatus that has been disassembled for the service or repair must be reassembled and checked after the service and repair work has been completed
- The predefined testing and service intervals found in the instruction manual must be adhered to
- Directions found in the instruction manual with regard to the exchange of parts are to be followed
- Operating personnel are to be informed before the commencement of special or refitting work
- The repair working area should be copiously secured
- During service or repair work, the crane system should be secured against unwarranted switching on
- Warning signs are to be placed
- The power cable is to be disconnected and secured against unwarranted connection
- Screw connections that have been loosened for repair or service work must be re-tightened
- Parts that are not reusable, such as O-rings, gaskets, self locking nuts, split-pins and washers are to be replaced

0.4 Notes on hazard protection

Hazard areas must be clearly marked by warning signs and secured by isolation.

It must be assured that the warnings regarding hazard areas are given due attention.

Hazards can stem from:

- Inexpert application
- Incomplete adherence to the safety directions
- Incomplete or inexact execution of test and service work

0.4.1 Hazards caused by mechanical influences

Human injury:



DANGER !

Unconsciousness and injury through:

- Crushing, shearing, cutting and twisting
- Retraction, expulsion, ramming and rubbing
- Slipping, stumbling and falling

Source:

- Crush, shear and twist area
- Breaching or bursting of parts

Protective possibilities:

- Floor, equipment and machinery are to be kept clean
- Eliminate leakages
- The safety distance must properly be observed

0.4.2 Hazards caused by electrical energy / power supply

Work on electrical apparatus or machinery may only be effected by qualified electricians or persons under the supervision and guidance of qualified electricians, in accordance with predefined electro-technical regulations.

Human injury:



DANGER !

Death through electrical shock, injury and burns through:

- Contact
- Faulty insulation
- Faulty servicing or repair work
- Short circuit

Source:

- Contact with, touching of or standing too close to non-insulated power and voltage supply terminals
- Free-lying electricity supply terminals following breakdown of insulation
- Inadequate execution of safety checks following repair work
- Incorrect fusing

Protection possibilities:

- Machinery and equipment designated for repair or service work should be isolated before commencement of such work
- First check isolated parts for voltage
- Regularly check the electrical fittings
- Immediately change loose or damaged cables
- Blown fuses must be replaced with fuses of the correct value
- Avoid contact or touch with live terminals
- Use only insulated tools

0.5 Technical status

The present document was written in 2000. It corresponds to no. 1.7.4 and no.4.4 of the appendage 1 in the version of the first alteration dated 20.06.91 (91/368/EWG) of the instruction of the European Rates from 14.06.89 (89/392/EWG).

0.5.1 Technical datas

0.5.1.1 Original sheet of the crane system

0.5.2 Recurrent checks

Each device/ unit operator has to adequately note all checks, maintenance and inspections performed into the inspection pass, and must have these confirmed by the competent person in charge. Incorrect or missing entries lead to forfeiture of the manufacturer's warranty.



CAUTION !

Devices and cranes are to be periodically tested by an expert. Basically, visual and functional checks are to be performed, whereby the condition of the components with regards to damage, wear, corrosion or other alterations are to be determined. Apart from this, the completeness and efficiency of the safety contrivance will be assessed.

In order to correctly value wearing parts, it may be necessary to dismantle the equipment under inspection.



CAUTION !

The carrying means must be inspected in their entire length, which implies even covered or hidden parts.



CAUTION !

All periodical inspections are to be arranged by the operator.

0.6 Operational parameters

The crane systems are manufactured in accordance with the latest technical developments along with the known technical safety regulations and specifications, and are tested for safety by the manufacturer.

The crane systems may only be used when in an acceptable technical condition, in accordance with their operating parameters, by safety and hazard conscious personnel.

The operational parameters of the crane systems also encompass the compliance of the pre-defined operating, service and maintenance requirements laid down by the manufacturer.

The operational parameters do not include:

- exceeding the defined load capacity
- diagonal pulling of the load
- heaving, pulling or dragging of the load

See also chapter 0.3

Inching operations, ground mooring and driving against the limit switches should be avoided.

The manufacturer accepts no responsibility for damage to equipment and third parties ensuing from such action.

0.6.1 Directions for the use of the instruction manual

This instruction manual includes the following chapters:

- 0 General directions
- 1 Assembly instructions
- 2 Start-up
- 3 Service and maintenance

Supplementary to the instruction manual, the following documentation from the operator must be noted:

- Declaration of conformity
- Inspection pass
- Spare parts list(s)
- Circuit diagrams

Page and figure numeration:

The pages are consecutively numbered. Empty pages are not numbered, however are calculated together with the consecutive pages.

Figures are numbered consecutively by chapter.

Example:

figure 1-1 means: in chapter 1, figure 1

1 Assembly instructions

1.1 Introduction

The crane system is based on two profiles: the GISKB I and the GISKB II. Certain accessories can be used for both profiles. The modular structure of the system ensures rapid and simple assembly.

During transport and assembly work, it is important to observe the special safety directions (chapter 0.3) for handling loads.

The crane system must be correctly assembled by skilled persons, observing the general accident prevention regulations (see chapter 0.2).

Prior to assembly, the components must be kept in an enclosed space, or under cover.

The GISKB system should be dimensioned and planned with the aid of the technical documentation or the calculation program. These documents contain information on the load that can be placed on the profiles, enabling the spans and suspension intervals to be established. They also contain the full range of components together with their dimensions and technical data.

1.1.1 Assembly requisites

Each crane system is assembled on the basis of a layout diagram that has been drawn up beforehand.



CAUTION !

The above layout diagram must be drawn in compliance with the technical documentation.

The diagram must contain the following details: dimensions of the crane system, maximum load capability, profile sizes, position of suspension points and profile connections, startup mass of crane hook, reference mass in three dimensions.

If key details are missing, these must be clarified before a start is made on assembly.



CAUTION !

Before starting on the assembly work, the material supplied must be checked to establish that it is correct and complete. The assembly staff must be provided with all the documents necessary for assembly.



CAUTION !

Mechanical and electrical assembly work may only be performed by duly authorised skilled workers.



CAUTION !

The operator bears responsibility for the load-bearing capacity of the building and the steel structure fitted at the customer's.



CAUTION !

Only original parts from GIS may be used for assembling GISKB systems.

1.2 Assembly of crane track or overhead monorail



NOTE

Before starting on the assembly work, the planned suspension points on the ceiling should be marked and checked. The points should be levelled out, and assembly commenced at the lowest point. The track route is best lined up using an appropriate aid (corde as a guide, laser, etc.).

1.2.1 Ceiling structure

All suspension types can be mounted on either a concrete ceiling or a steel structure using the GISKB standard components.

a) Concrete ceiling (Figure 1-1)

For mounting onto a concrete ceiling, the pre-assembled ceiling clip (1) must be mounted on the two anchor bolts (2).



CAUTION !

The spacing between the two bolts must be within the specified tolerance. The load-bearing capacity of the bolts must correspond to the specified ceiling load. The customer is responsible for the quality of the concrete. A washer must be placed between the nut and the ceiling clip.

b) Steel structure (Figure 1-2)

The pre-assembled ceiling clip (1) is mounted on the steel beam by means of two binding clips (2).



CAUTION !

The flange dimensions must be within the specified tolerances, see figure 1-2. The screw of the binding clip must rest on the flange of the steel beam. Both nuts must be secured with safety plates.

1.2.2 Suspension pendulating short (Figure 1-1)

- completely pre-assemble the suspension as per figure 1-1



CAUTION !

The sliding surface between ball pin resp. ball nut and plastic ring must be lubricated.

- undo the screw connection to the two sliding blocks (3) until these can be rotated through 90°
- place the pre-assembled suspension on the profile and position the sliding blocks in the profile groove at right angles to the direction of travel of the track. Tighten the nuts so that the sliding blocks can no longer be rotated
- position the suspensions at the correct point of the crane track
- lift up the crane track and mount on the ceiling structure in question (see chapters 1.2.1 and 1.2.2)
- level out the crane track. The suspension height can be levelled out by up to 15 mm by screwing the ball pin (4) in and out.



WARNING !

Safety elements must be mounted.

1.2.3 Suspension pendulating from rod (Figure 1-3)

- completely pre-assemble the suspension as per figure 1-3



NOTE

For suspensions from rod with several threaded rods latter are connected to the coupling (1).

- proceed further as in chapter 1.2.2



NOTE

A height adjustment of 30 mm is possible for rod-suspended systems.

1.2.4 Bracing pendulating from rod (Figure 1-3)

- pre-assemble the bracing as per figure 1-3
- the distance between the lower node (2) and the ball pin of the suspension must not exceed 10 mm

1.2.5 Rigid suspension (Figure 1-4)

- mount the entire rigid suspension (1) on the ceiling clip (2) and secure the crown nut with a cotter pin
- proceed further as set out in chapter 1.2.2



NOTE

A crane track with a rigid suspension system cannot be levelled out.

1.2.6 Joining profiles (Figure 1-5; cover Figure 1-6)

- an end plate is welded to the end of each profile
- two profiles are joined together with four hexagon bolts
- a cover is placed over the end of the profile; the rubber buffers and screws are included in the delivery.

1.3 Assembly of the crane bridge

1.3.1 Single crane bridge

a) Suspension on a trolley (Figure 1-7; Figure 1-8)



CAUTION !

Suspension on a trolley is only possible with a pendulating suspension system.

- completely assemble the crane bridge suspension and join up to the crane bridge and the trolley

To permit adjustments to the precise distance between tracks and to the height, the screw connections should not be tightened at the pre-assembly stage.

- insert the crane bridge into the mounted crane track
- precisely adjust the distance and height
- secure the screw connections

b) Suspension on rolling apparatus (Figure 1-9)

- mount EQB rolling apparatus on the crane bridge profile
- do up screws loosely

- guide crane bridge into the crane track
- tighten the screw connections
- function check: move the crane bridge over the full length of the crane track

1.3.2 Double crane bridge (Figure 1-10)

- mount DQB rolling apparatus on the crane bridge profile
- proceed further as in chapter 1.3.1 b)

1.3.3 Profile reinforcement (Figure 1-11)

The profile reinforcement is clamped on the profile section. The dimensions of figure 1-11 are strictly to be adhered to.

1.3.4 Combination of trolleys

- Simple trolley figure 1-12
- Coupled trolley figure 1-13
- Saddle figure 1-10



CAUTION !

The contact surfaces of the supporting bolts must be lubricated at the assembly.

1.4 Electrical equipment



NOTE

The electrical equipment supplied includes all the parts up to the terminal box at the end of the track. The main switch, fuses and feed lines must be installed and laid by the customer.

1.4.1 Trailing cable in the profile



CAUTION !

The cable loops must be selected so that they do not obstruct work with the crane. With straight sections of track, a distance between cable carriages of approx. 1.5 to 2 m is recommended. For curves and points, the distance should be approx. 1.0 m.

Assembling the traction limit (figure 1-14): the traction limit protects the cable carriages. The hole (dia 11) is made during assembly.

a) Monorail (Figure 1-15)

The flat cable is led from the terminal box via the cable carriages and the fixed point clamp into the electric hoist. For curves and switches, the curvegoing cable carriages should be used.

b) Suspended crane (Figure 1-15)

Here, the flat cable is led from the terminal box via the cable carriages and the fixed point clamp to the terminal box of the crane bridge. From this terminal box it is taken to the electric hoist. See under a) Monorail.

1.4.2 Trailing cable on C-rail (Figure 1-16)

The C-rails are fastened to the profile by means of clamping devices. The same applies for the cable loops as for a trailing cable inside the profile.

Assembly is performed in the manner shown in figure 1-16.

1.4.3 Conductor line (Figure 1-17)

The current is fed to the conductor line from the terminal box at the end of the track.

Further assembly details may be found in the manufacturer's assembly instructions and in figure 1-17.

2 Start-up

The start-up is performed together with the operator and is entered in writing in the original sheet of the crane system.

2.1 Checks following installation and adjustment

2.1.1 Check the fuses

Check the upstream fuses. Make sure that the fuses of the crane system have the appropriate rating.

2.1.2 Check on electric connections

- check that electric feed lines are reliably routed and securely fastened



CAUTION !

- avoid trapping, rubbing and squeezing cables
- check cable clamps and fixing materials are securely fastened

2.1.3 Functional checks

During the start-up the crane system must be checked with the nominal load. A suitable test weight must be put at the disposal by the operator.

The dimensions and the runs are checked in compliance with the layout diagram.

The functions of the crane system must be in accordance with the description of the order confirmation.

Load plates must be affixed, well legible, on the crane system.

2.1.4 Operation

For the operation the safety directions of chapter 0 must be observed strictly.

3 Service and maintenance

3.1 General regulations for service- and maintenance work

Operating failures on the crane systems impairing the safe operation of the device are to be cleared immediately.

The crane system may only be serviced by trained and authorized specialists.



NOTE

We recommend to have maintenance work performed by our customer service.



CAUTION !

If the operator performs maintenance work on a crane system on his own account, the type of maintenance performed must be entered together with the date of performance into the inspection pass.

Alterations to, as well as changes of and supplements to the crane system which may impair the safety must be authorized by the manufacturer in advance. Constructional alterations to the crane system not authorized by the manufacturer lead to an exclusion of the manufacturer's liability in case of damage.

Material warranty claims will only be recognized if solely genuine spare parts by the manufacturer have been employed. We explicitly wish to point out that original parts and accessories not supplied on our behalf cannot be inspected or released by us.

General:

Service and maintenance are preventive measures designed to enhance the full functionality of the crane systems. Non-compliance with the service and maintenance routines can result in reduction of the useful function of and/or damage to the crane systems. Service and maintenance work is, in accordance with the instruction manual, to be effected at the predefined time intervals (table 3-1 and 3-2).

During service and maintenance work the general accident prevention directions, the special safety directions (chapter 0.3) as well as the notes on hazard protection (chapter 0.4) are to be followed.



DANGER !

Service and maintenance work is only to be effected on unloaded crane systems. The main switch must be off.

The maintenance work encompass sight checks and cleaning routines.

The service work includes additional functional checks.

During the functional checks, all securing elements and cable clamps must be checked for secure seating. Cables must be inspected for dirt, discoloration and arc spots.



CAUTION !

Used operating fuels (oil, lubricants ...) are to be safely collected and disposed of in an environmentally friendly manner.

Service and maintenance intervals are so defined:

- t: daily
- 3 M: quarterly
- 12 M: annualy

The predefined service and maintenance intervals are for standard operating hours.

They are to be reduced when the loading of the crane systems is on average large and when unfavourable conditions surface frequently during operation (dust, heat, humidity, steam, etc.).

3.2 Maintenance

3.2.1 Maintenance summary

See table 3-1

3.3 Service

3.3.1 Service summary

See table 3-2

3.4 Ordering of spare parts

Notes on how to order spare parts can be found on page 2.

On page 10 is shown a list with all the standard crane components.

Table 3-1

Designation	t	3 M	12 M	Activity
1 Safety elements		X		Visual check
2 Trolley, rolling apparatus		X		Check on unusual noise and wear
3 Electrical connections	X			Visual check on abrasion and wear
4 Suspension points		X		Visual check on wear

Table 3-2

Designation	t	3 M	12 M	Activity
1 Screw connections			X	Check on starting torque of screws
2 Safety elements			X	Function test
3 Trolley, rolling apparatus			X	Visual check on wear, lubrication of contact surfaces
4 Electrical fittings			X	Check on abrasion and wear
5 Suspension points			X	Re-lubrication of contact surfaces on plastic ring
6 Load of installation			X	Function check with nominal load

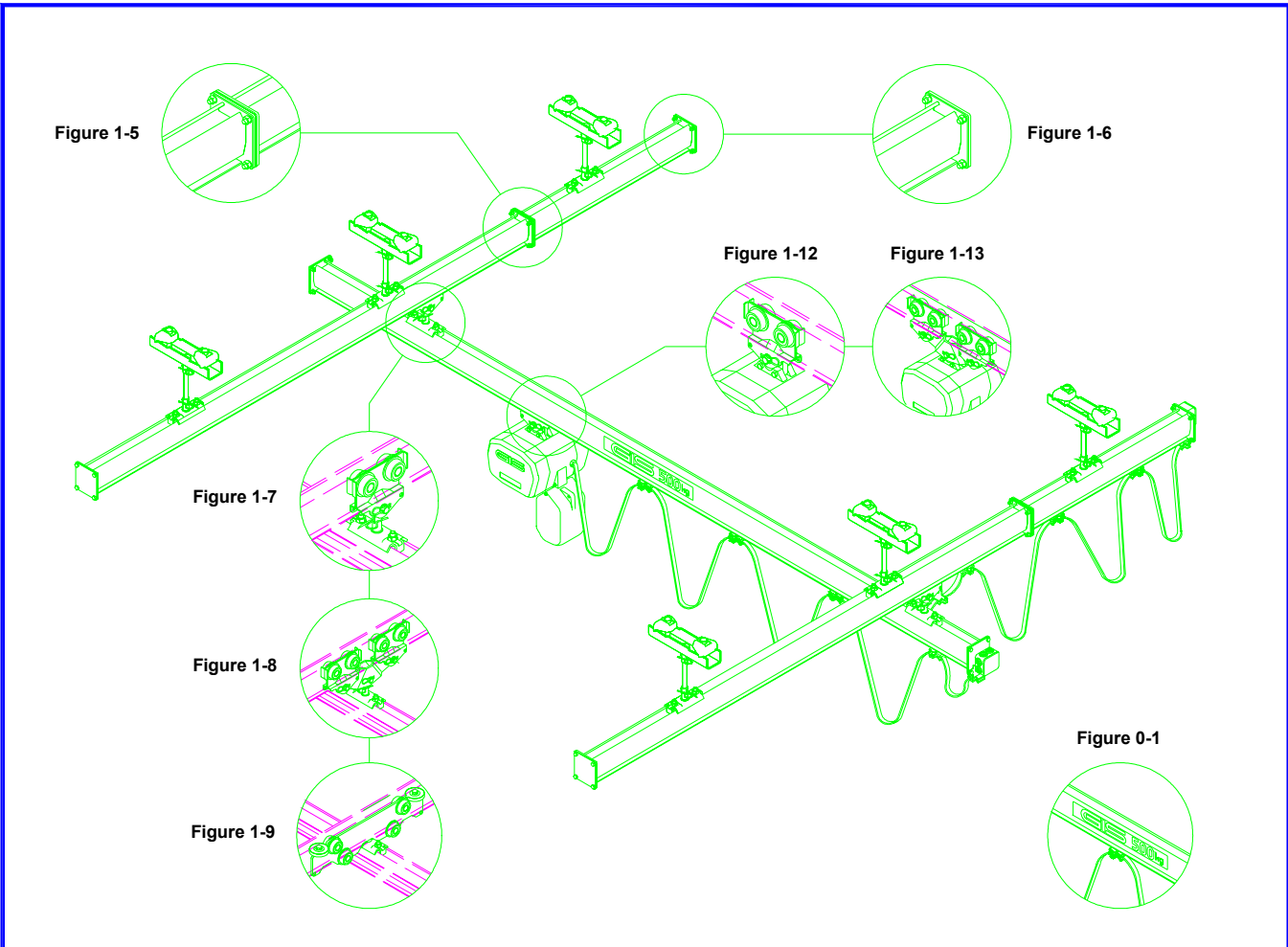

Figure 1-1

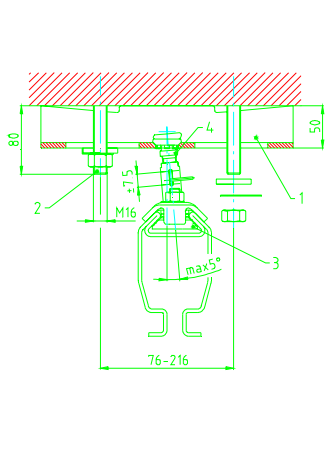

Figure 1-2

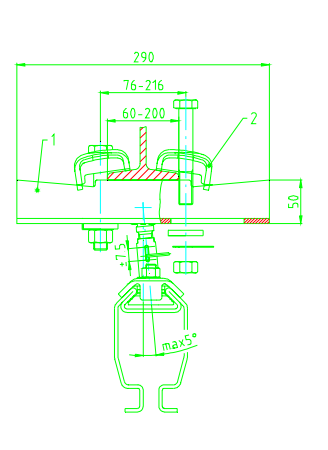

Figure 1-3

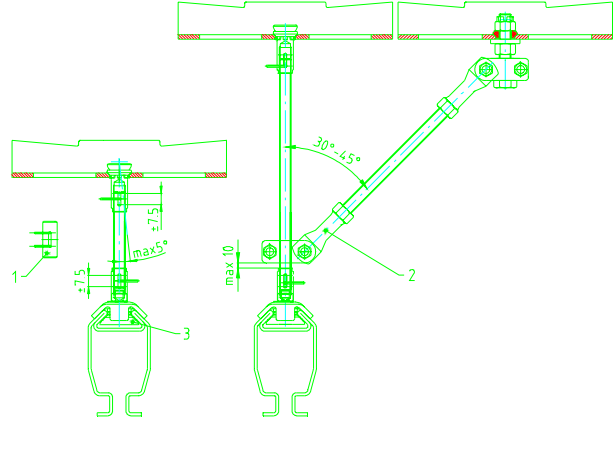

Figure 1-4

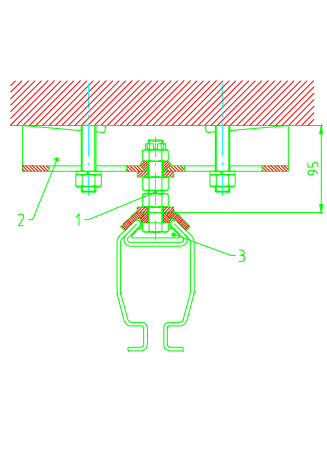

Figure 1-10

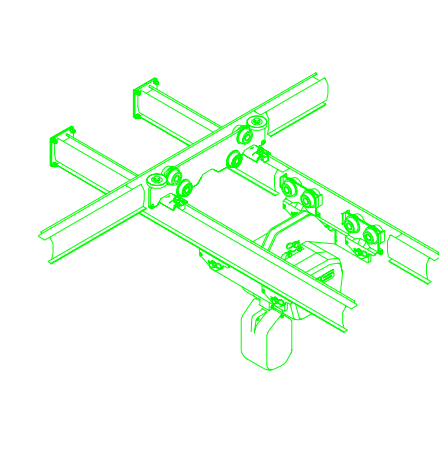
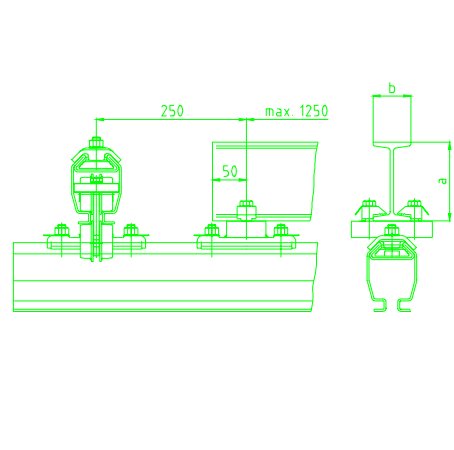

Figure 1-11



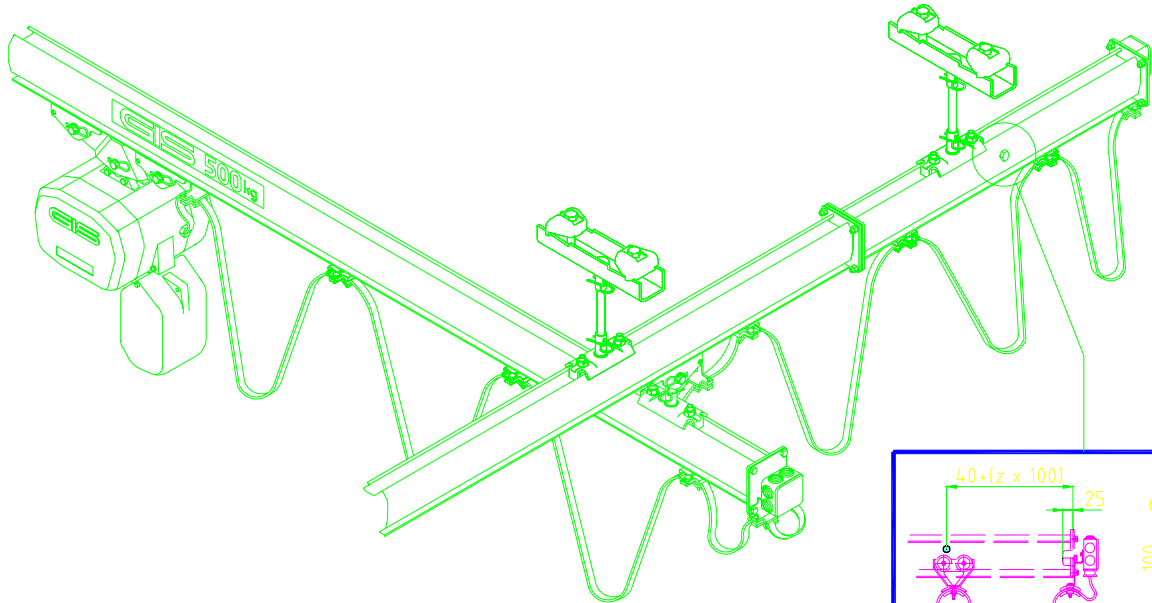

Figure 1-15

Figure 1-14

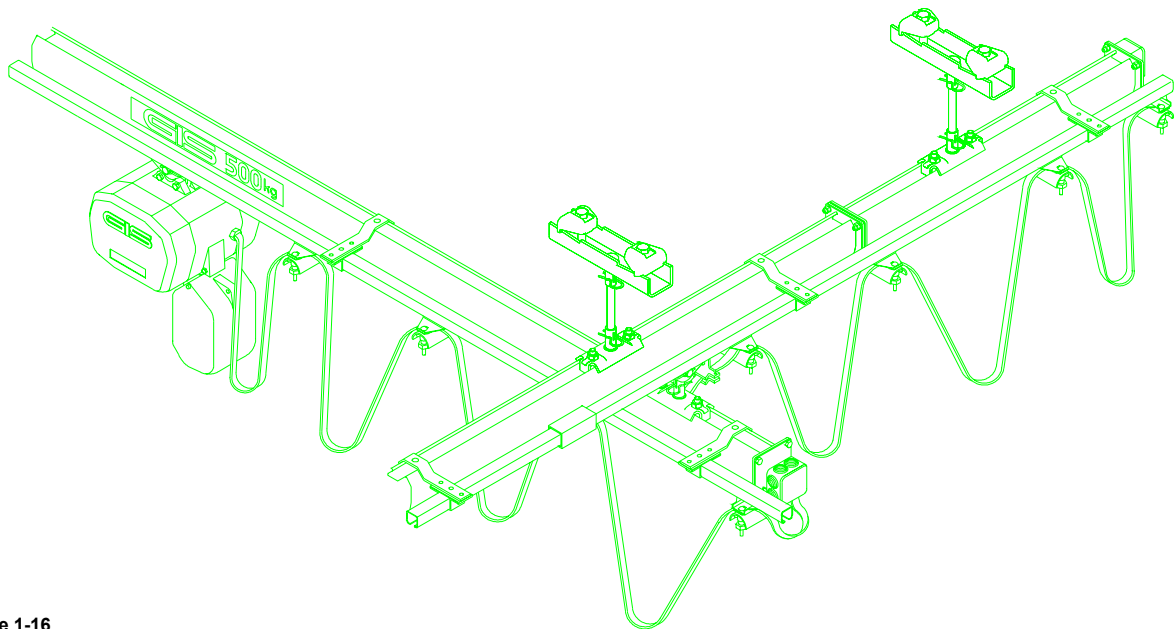

Figure 1-16

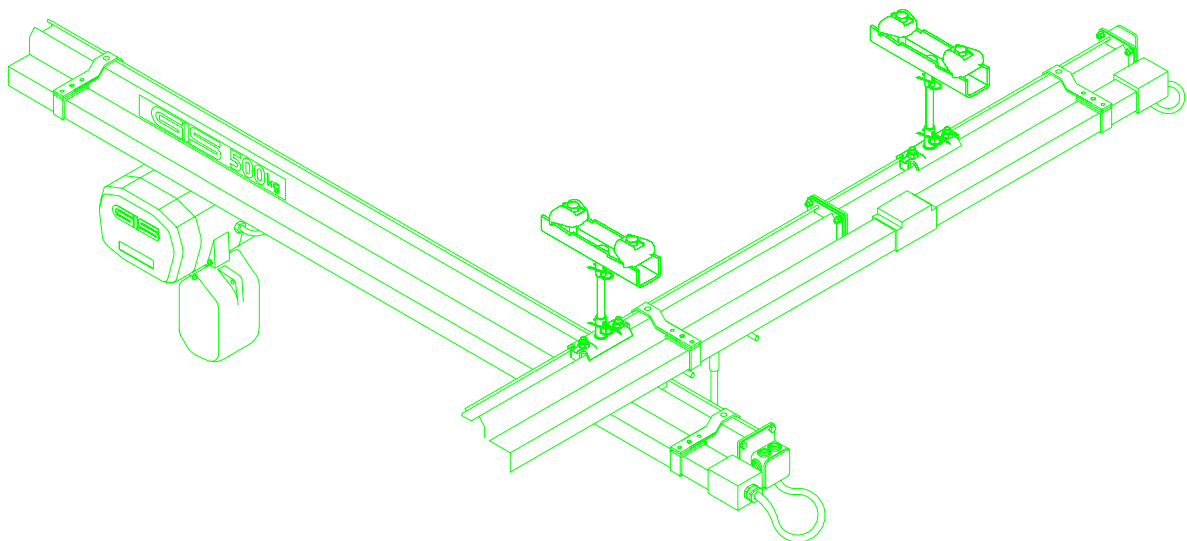

Figure 1-17

Standard crane components GISKB

Ref. no.	Designation	Weight [kg]
9031.4402	Safety plate M12, VZ, DIN463	0.005
9031.4402P	Safety plate M12, VZ, DIN463, 100 pieces	0.500
9031.4403	Safety plate M16, VZ, DIN463	0.006
9031.4403P	Safety plate M16, VZ, DIN463, 100 pieces	0.600
9055.0300	Cable, 4x1.5mm2, Fk	0.130
9055.0301	Cable, 5x1.5mm2, Fk	0.170
9055.2753	Enlargement Pg16/21	0.050
9055.3010	Cable gland Pg16 PVC, RD	0.030
9055.3014	Cable gland Pg21 MS, Fk	0.050
9055.3016	Cable gland Pg29 MS, Fk	0.060
9055.3018	Cable gland Pg36 MS, Fk	0.070
9055.3024	Cable gland Pg16 MS, Fk	0.050
9055.4004	Counternut Pg16	0.005
9057.0103	Suspension, VA806	0.050
9057.0104	Fixed suspension, VA850	0.050
9057.0151	End cap, VA802	0.100
9057.0254	Power feed, EV04	0.100
9057.0400	Current collecting trolley, PM425C	0.600
9057.0552	Connection cap, VA804	0.100
9057.4100	Cable end clamp, C-rail	0.200
9057.4150	Connector, C-rail	0.300
9057.4200	Suspension, C-rail	0.250
9057.4250	Cable trolley, C-rail	0.300
9057.4300	C-rail stop	0.150
9305.1000.9	Track section GISKB I, raw, 8m	9.600
9305.1000.B	Profile GISKB I, bundle at 15x8m = 120m, raw	1160.000
9305.1001.4	End plate GISKB I, raw	0.200
9305.1002.4	Cover GISKB I	0.400
9305.1003.4	Profile connection GISKB I	0.010
9305.1005.4	Track section 1m, GISKB I, primed	10.000
9305.1006.4	Track section 2m, GISKB I, primed	19.600
9305.1007.4	Track section 3m, GISKB I, primed	29.600
9305.1008.4	Track section 4m, GISKB I, primed	38.800
9305.1009.4	Track section 5m, GISKB I, primed	48.400
9305.1010.4	Track section 6m, GISKB I, primed	58.000
9305.1011.4	Track section 7m, GISKB I, primed	67.600
9305.1012.4	Track section 8m, GISKB I, primed	77.200
9305.1020.3	Trolley GISKB I	1.500
9305.1022.3	Rolling apparatus EQB, GISKB I	5.500
9305.1023.3	Rolling apparatus DQB, GISKB I	6.000
9305.1030.4	Track section 0-1m, GISKB I, primed	10.000
9305.1031.4	Track section 1-2m, GISKB I, primed	19.600
9305.1032.4	Track section 2-3m, GISKB I, primed	29.600
9305.1033.4	Track section 3-4m, GISKB I, primed	38.800
9305.1034.4	Track section 4-5m, GISKB I, primed	48.400
9305.1035.4	Track section 5-6m, GISKB I, primed	58.000
9305.1036.4	Track section 6-7m, GISKB I, primed	67.600
9305.1037.4	Track section 7-8m, GISKB I, primed	77.200
9306.1000.9	Track section GISKB II, raw, 8m	15.000
9306.1000.B	Profile GISKB II, bundle at 8x8m = 64m, raw	970.000
9306.1001.4	End plate GISKB II, raw	0.500
9306.1002.4	Cover GISKB II	0.700
9306.1003.4	Profile connection GISKB II	0.200
9306.1005.4	Track section 1m, GISKB II, primed	16.000
9306.1006.4	Track section 2m, GISKB II, primed	31.000
9306.1007.4	Track section 3m, GISKB II, primed	46.000
9306.1008.4	Track section 4m, GISKB II, primed	61.000
9306.1009.4	Track section 5m, GISKB II, primed	76.000
9306.1010.4	Track section 6m, GISKB II, primed	91.000
9306.1011.4	Track section 7m, GISKB II, primed	106.000
9306.1012.4	Track section 8m, GISKB II, primed	121.000
9306.1020.3	Trolley GISKB II	2.000
9306.1022.3	Rolling apparatus EQB, GISKB II	6.500
9306.1023.3	Rolling apparatus DQB, GISKB II	7.000
9306.1030.4	Track section 0-1m, GISKB II, primed	16.000
9306.1031.4	Track section 1-2m, GISKB II, primed	31.000
9306.1032.4	Track section 2-3m, GISKB II, primed	46.000
9306.1033.4	Track section 3-4m, GISKB II, primed	61.000
9306.1034.4	Track section 4-5m, GISKB II, primed	76.000
9306.1035.4	Track section 5-6m, GISKB II, primed	91.000
9306.1036.4	Track section 6-7m, GISKB II, primed	106.000
9306.1037.4	Track section 7-8m, GISKB II, primed	121.000
9309.1049.3	Load plate, neutral	0.030
9309.1051.3	Load plate, 125 kg	0.030
9309.1052.3	Load plate, 250 kg	0.030
9309.1053.3	Load plate, 500 kg	0.030
9309.1055.3	Load plate, 1000 kg	0.030
9309.1066.3	Load plate, 160 kg	0.030
9309.1067.3	Load plate, 200 kg	0.030
9309.1068.3	Load plate, 320 kg	0.030
9309.1069.3	Load plate, 400 kg	0.030
9309.1070.3	Load plate, 630 kg	0.030
9309.1071.3	Load plate, 800 kg	0.030
9309.1072.3	Load plate, 1250 kg	0.030
9309.1073.3	Load plate, 1600 kg	0.030
9309.3000.4	Sliding block, GISKB I+II	0.120
9309.3000P	Sliding block, GISKB I+II, 100 pieces	12.200

Ref. no.	Designation	Weight [kg]
9309.3002.4	Profile retainer raw, GISKB I+II	0.500
9309.3003.3	Ceiling clip, GISKB I+II	2.000
9309.3005.4	Binding clip complete, GISKB I+II	0.600
9309.3006.4	Ring, GISKB I+II	0.002
9309.3006P	Ring, GISKB I+II, 100 pieces	0.200
9309.3007.4	Spring retention, GISKB I+II	0.009
9309.3007P	Spring retention, GISKB I+II, 100 pieces	0.900
9309.3010.4	Ball pin complete, GISKB I+II	0.120
9309.3011.4	Ball nut complete, GISKB I+II	0.160
9309.3013.4	Suspension fixed, GISKB I+II	1.250
9309.3015.4	Lower node, GISKB I+II	0.300
9309.3016.4	Upper node, GISKB I+II	0.600
9309.3020.3	Traverse, GISKB I+II	2.000
9309.3021.3	Saddle, GISKB I+II	7.100
9309.3024.4	Screwed rod H=210 mm, GISKB I+II	0.100
9309.3025.4	Screwed rod H=310 mm, GISKB I+II	0.200
9309.3026.4	Screwed rod H=410 mm, GISKB I+II	0.400
9309.3027.4	Screwed rod H=610 mm, GISKB I+II	0.650
9309.3028.4	Screwed rod H=1110 mm, GISKB I+II	1.200
9309.3031.4	Clamping holder complete, GISKB I+II	2.000
9309.3032.4	Profile retainer complete, GISKB I+II	0.800
9309.3033.4	Coupling complete, GISKB I+II	0.150
9309.3036.4	Traction limit, GISKB I+II	0.080
9309.3037.4	Terminal box complete, GISKB I+II	0.300
9309.3040.4	Cable carriage, GISKB I+II	0.120
9309.3041.4	Cable carriage curvengoing, GISKB I+II	0.130
9309.3045.4	Clamping device, GISKB I+II	0.400
9309.3046.4	C-rail, 1m	1.500
9309.3047.4	C-rail, 2m	3.000
9309.3048.4	C-rail, 3m	4.500
9309.3049.4	C-rail, 4m	6.000
9309.3050.4	C-rail, 5m	7.500
9309.3051.4	C-rail, 6m	9.000
9309.3052.4	C-rail, 0-0.99m	1.500
9309.3053.4	C-rail, 1.01-1.99m	3.000
9309.3054.4	C-rail, 2.01-2.99m	4.500
9309.3055.4	C-rail, 3.01-3.99m	6.000
9309.3056.4	C-rail, 4.01-4.99m	7.500
9309.3057.4	C-rail, 5.01-5.99m	9.000
9309.3058.4	Conductor line, 1m, VA34	1.100
9309.3059.4	Conductor line, 2m, VA34	2.200
9309.3060.4	Conductor line, 3m, VA34	3.300
9309.3061.4	Conductor line, 4m, VA34	4.400
9309.3062.4	Conductor line, 5m, VA34	5.500
9309.3063.4	Conductor line, 0-0.99m, VA34	1.100
9309.3064.4	Conductor line, 1.01-1.99m, VA34	2.200
9309.3065.4	Conductor line, 2.01-2.99m, VA34	3.300
9309.3066.4	Conductor line, 3.01-3.99m, VA34	4.400
9309.3067.4	Conductor line, 4.01-4.99m, VA34	5.500
9309.3068.4	Crane bridge suspension, GISKB I+II	1.150
9309.3069.4	Cable fixing part, GISKB I+II	0.040
9309.3070.4	Driving pin, GISKB I+II	0.110
9309.3071.4	Connection cable, GISKB I+II	0.200
9309.3072.4	Profile reinforcement INP120, 0.001-2.0m	22.000
9309.3073.4	Profile reinforcement INP120, 2.001-3.0m	33.000
9309.3074.4	Profile reinforcement INP120, 3.001-4.0m	44.000
9309.3075.4	Profile reinforcement INP120, 4.001-5.0m	55.000
9309.3076.4	Profile reinforcement INP120, 5.001-6.0m	66.000
9309.3077.4	Profile reinforcement INP120, 6.001-7.0m	77.000
9309.3078.4	Profile reinforcement INP120, 7.001-8.0m	88.000
9309.3079.4	Profile reinforcement INP160, 0.001-2.0m	36.000
9309.3080.4	Profile reinforcement INP160, 2.001-3.0m	54.000
9309.3081.4	Profile reinforcement INP160, 3.001-4.0m	72.000
9309.3082.4	Profile reinforcement INP160, 4.001-5.0m	90.000
9309.3083.4	Profile reinforcement INP160, 5.001-6.0m	108.000
9309.3084.4	Profile reinforcement INP160, 6.001-7.0m	126.000
9309.3085.4	Profile reinforcement INP160, 7.001-8.0m	144.000
9309.3086.4	Profile reinforcement INP180, 0.001-2.0m	44.000
9309.3087.4	Profile reinforcement INP180, 2.001-3.0m	66.000
9309.3088.4	Profile reinforcement INP180, 3.001-4.0m	88.000
9309.3089.4	Profile reinforcement INP180, 4.001-5.0m	110.000
9309.3090.4	Profile reinforcement INP180, 5.001-6.0m	132.000
9309.3091.4	Profile reinforcement INP180, 6.001-7.0m	154.000
9309.3092.4	Profile reinforcement INP180, 7.001-8.0m	176.000
9310.5011.4	Connector clamp trolley, GISKB I+II	0.200
9310.5012.4	Connector clamp rolling apparatus, GISKB I+II	0.200
SAKBN.Br	Electric tug complete with brake	14.600
SAKBN.Br/FU	Electric tug complete with brake, FU	15.100