

Instruction manual electric tug (SA)

Spare parts

Ersatzteile
Pièces de rechange
Onderdelen
Reservedele
Varaosat
Pezzi di ricambio
Reservedeler
Peças
Reservdelar
Piezas de recambio

Circuit diagrams

Stromlaufpläne
Schéma de connexions
Stroomschema
Kredslobsdiagrammer
Kytkentäkaavio
Aanluitschema
Schema elettrico
Koplingskjema
Esquema electrico
Elschema
Esquema eléctrico

SAKB



TABLE OF CONTENTS

	Page		Page
0	General directions	3	
0.1	General safety directions	3	
0.1.1	Safety and hazard precautions	3	
1	General functional description	3	
1.1	Control system	3	
1.2	Control elements	3	
1.3	Motor/Brake/Gear	3	
1.4	Friction wheel drive with trolley	3	
2	Start-up	3	
2.1	Transport and assembly	3	
2.2	Connection	3	
2.2.1	Power connection for operating voltage	3	
2.2.2	Earth connections	3	
2.2.3	Adjustment of travelling speed	3	
2.2.4	Assembly within the profile	4	
2.3	Further checks following assembly and installation	4	
2.3.1	Check the fuses	4	
2.3.2	Electrical connection check	4	
3	Maintenance	4	
3.1	General regulations for service- and maintenance work	4	
3.2	Service and maintenance	4	
3.3	Ordering of spare parts	4	
4	Spare parts list	6	
5	Circuit diagrams	7	

Spare parts / Ordering of spare parts

The correct order numbers for the original spare parts are to be taken from the spare parts list. Please ensure that you have the following data on your electric tug (SA) to hand. Thereby a quick and correct supply of the parts required will be effected.

Electric tug type :

Manufacture number :

Year of manufacture :

Original spare parts for the electric tug (SA) can be acquired from the following addresses:

1. Manufacturer

GIS AG
 Hebe- und Fördertechnik
 Luzernerstrasse 50
 CH-6247 Schötz

2. Agent

.....

.....

.....

.....

0 General directions

0.1 General safety directions

0.1.1 Safety and hazard precautions

The following symbols and terms are used in this instruction manual for safety and hazard instructions:



DANGER !

The non-compliance either in part or full of work and operational directions marked with this symbol can result in serious personal injury or even death. Danger notices must be **strictly** complied with.



CAUTION !

The non-compliance either in part or full of work and operational directions marked with this symbol can result in major machinery, property or material damage. Cautionary notices must be **strictly** adhered to.



NOTE

Effective and simple operation is the result of following the directions denoted under this symbol. "Note" directions make light work.

For general directions and safety specifications: see chapter 0 of the instruction manual for electric chain hoists and travel trolleys (9215.9000).

The technical datas can be found in the GISKB documentation on page 29.

1 General functional description

The electric tug (SA) is delivered with or without control system. The same SA is suitable for both GISKB I and GISKB II profiles.

1.1 Control system (Figure 1-1 / 1)

The electric tug (SA) is controlled in series with a frequency changer (FU) and adjustable for one or two travelling speeds. The acceleration and deceleration time can be regulated.

1.2 Control elements

The control switch for the SA (electric tug) has 4 or 6 buttons. The control cable is conducted into the control box.

1.3 Motor / Brake / Gear (Figure 1-1 / 2)

The electric tug (SA) is equipped with a cylindrical asynchronous motor and generally with a direct-current brake. The winding is of insulation class F. The transmission is assured by a two-stage spur gearing which is continuously lubricated.

1.4 Friction wheel drive with trolley (Figure 1-1 / 3)

The vulcolan-coated friction wheel is pressed outside to the lateral side of the lower profile part. The pressing power can be regulated by two tension screws. The trolley within the profile section is equipped with four plastic rollers.

2 Start-up



DANGER !

Mechanical adjustments may only be performed by authorized specialists.



CAUTION !

The operating staff must carefully read the instruction manual of the SA before its initial operation and carry out all checks. Only when a safe operation has been established may the device be put into operation. Unauthorized persons may not operate the device or perform any work with the help of the same.

2.1 Transport and assembly

For the transport and assembly of the electric tug (SA), the safety direction for handling with loads are to be followed (see chapter 0). The SA must be assembled by qualified staff, always bearing in mind the accident prevention directions in chapter 0. Before assembly the SA must be stored in an enclosed room or covered area.

Should the SA be destined for operation outdoors, then it is recommended that a protection roof is erected to shield it from the influences of the weather.

Wherever possible, the SA should be transported in its original packaging. It is recommended that the assembly and connection of it is effected on-site by our qualified customer service personnel.

2.2 Connection

2.2.1 Power connection for operating voltage



DANGER !

Electrotechnical adjustments may only be performed by authorized specialists.



CAUTION !

Before connection of the SA, check to ensure that the voltage defined on the load plate is the same as that which is available. Remove the electrical cover plate and connect the power cable in the side tappings (PG 16).

The SA must be connected according to the supplied circuit diagrams.

The connection cable for a second non-controlled electric tug must be of shielded type and 4 x 1 mm².

2.2.2 Earth connections



DANGER !

The protective conductor is not to carry any power. The use of a shielded cable requires the shielding to be earthed.



NOTE

The earth conductor is wired up to the earth connection terminal as green/yellow wire. Earth conductor of the power supply to the terminal (PE) is connected with yellow/green wire.

2.2.3 Adjustment of travelling speed

The SA is equipped in series with a frequency changer. The adjustment of four parameters is possible:

RA	Acceleration resp. deceleration normal speed
N	Max. frequency high speed max. 85 Hz
F	Max. frequency small speed
Boost	Torque moment

2.2.4 Assembly within the profile

The hexagon nuts M10 must be loosened so that the SA can be introduced in the profile section. After that introduction the two hexagon nuts are equally prestressed. The disk springs should not be stressed totally.



CAUTION !

The profile must be free from oil and grease.

The connector clamp assures the adequate coupling of the SA with the trolley (figure 2-1) or with the rolling apparatus (figure 2-2).

2.3 Further checks following assembly and installation

2.3.1 Check the fuses

Check the fuses in the tool box.



DANGER !

The value of the fitted fuses must be dimensioned according to the motor power of all the devices of the crane system.

2.3.2 Electrical connection check

- Check electrical power supply run is safely seated and secure in its path



CAUTION !

- Avoid clamping, knotting and crushing of cable
- Check cable clamps and securing material are securely seated
- With external traction relief check the security of the traction relief cable for the control switch



CAUTION !

The traction relief cable must be so secured that the power cable for the control switch is not put under stress.

3 Maintenance

3.1 General regulations for service- and maintenance work

Operating failures on the SA impairing the safe operation of the device are to be cleared immediately.

The SA may only be serviced by trained and authorized specialists.



NOTE

We recommend to have maintenance work performed by our customer service.



CAUTION !

If the operator performs maintenance work on an SA on his own account, the type of maintenance performed must be entered into the inspection pass together with the date of performance.

Alterations to, as well as changes of and supplements to the SA which may impair the safety must be authorized by manufacturer in advance. Alterations to the SA not authorized by the manufacturer lead to an exclusion of the manufacturer's liability in case of damage.

Material warranty claims will only be recognized if solely genuine spare parts by the manufacturer have been employed.

We explicitly wish to point out that original parts and accessories not supplied on our behalf cannot be inspected or released by us.

General:

Service and maintenance are preventive measures designed to enhance the full functionality of the SA. Non-compliance with the service and maintenance routines can result in reduction of the useful function of and/or damage to the equipment. Service and maintenance work are to be effected periodically in accordance with the instruction manual.

During service and maintenance work the general accident prevention directions, the special safety directions (chapter 0) as well as the notes on hazard protection (chapter 0) are to be followed.



DANGER !

Service and maintenance work is only to be effected on the unloaded SA. The main switch must be off.

The maintenance work encompass sight checks and cleaning routines.

The service work includes additional functional checks.

During the functional checks, all securing elements and cable clamps must be checked for secure seating. Cables must be inspected for dirt, discoloration and arc spots.



CAUTION !

Used operating fuels (oil, lubricants ...) are to be safely collected and disposed of in an environmentally friendly manner.

The service and maintenance intervals are to be adapted to the working conditions. They are to be reduced when the working stress of the SA is on average large and when unfavourable conditions surface frequently during operation (dust, heat, humidity, steam, etc.).

3.2 Service and maintenance

The following sight checks are to be made daily:

- Wear of friction wheel; if the friction wheel slips, it requires more prestress
- Sealing of gear; no oil or grease should penetrate
- Current supply cable; no chaff marks or damages are allowed
- Discharging device of cable; the cable should not be put under stress

The friction wheel must be replaced as soon as the holding device grazes the profile.

Replacement of friction wheel:

- a) Cut-off current
- b) Remove SA from profile
- c) Detach friction wheel according to figure 3-1



CAUTION !

The SA must periodically be maintained.

Adequate maintenance requires the SA to be removed from the profile. The following maintenance works are to be made:

- Check on wear and quiet running of the friction wheels
- Replace any worn-out friction wheel
- Check sealing of the gear
- Replace any damaged cables or cable glands

The maintenance work must be followed by a functional check with nominal load.

3.3 Ordering of spare parts

Notes on how to order spare parts can be found on page 2.

Figure 1-1

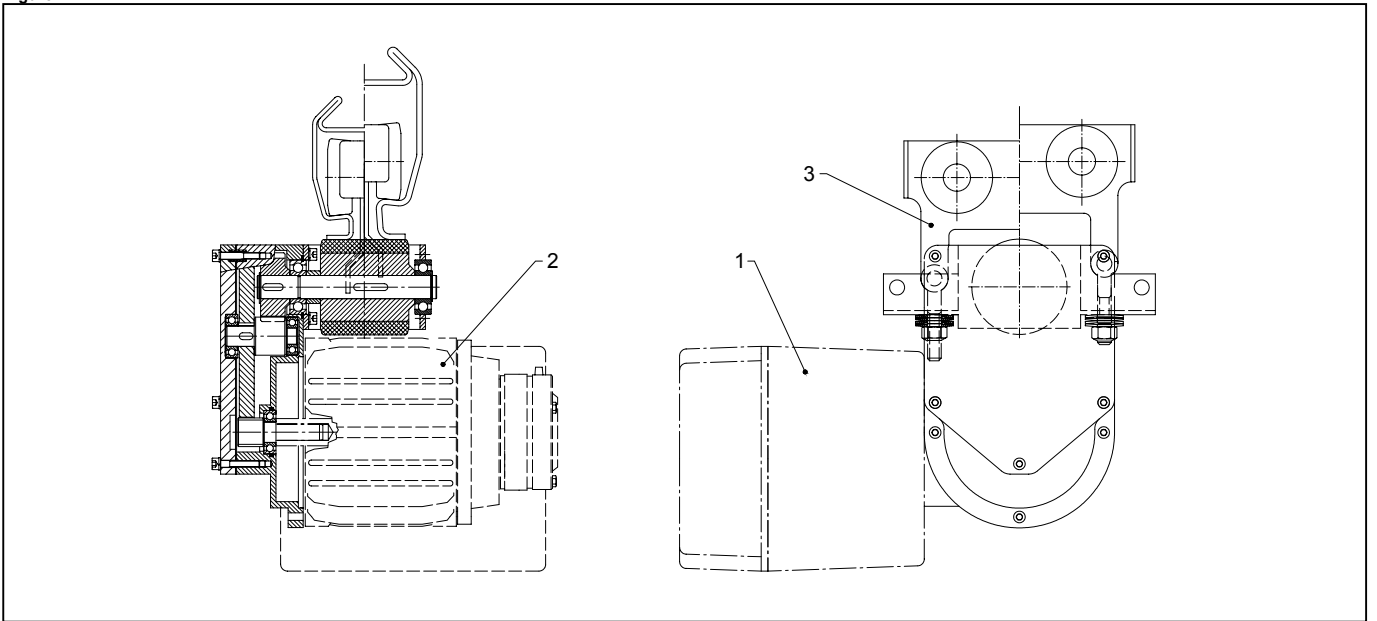

Figure 2-1

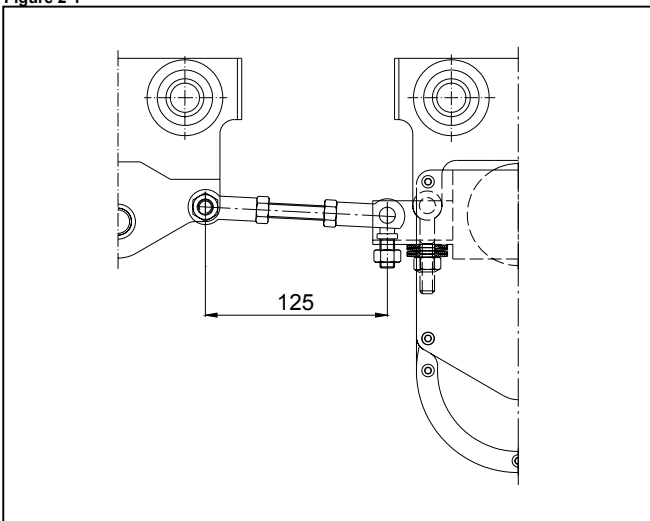

Figure 2-2

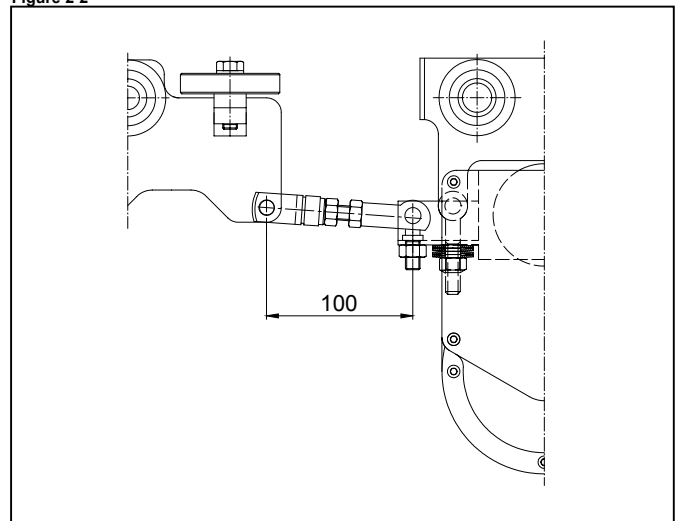
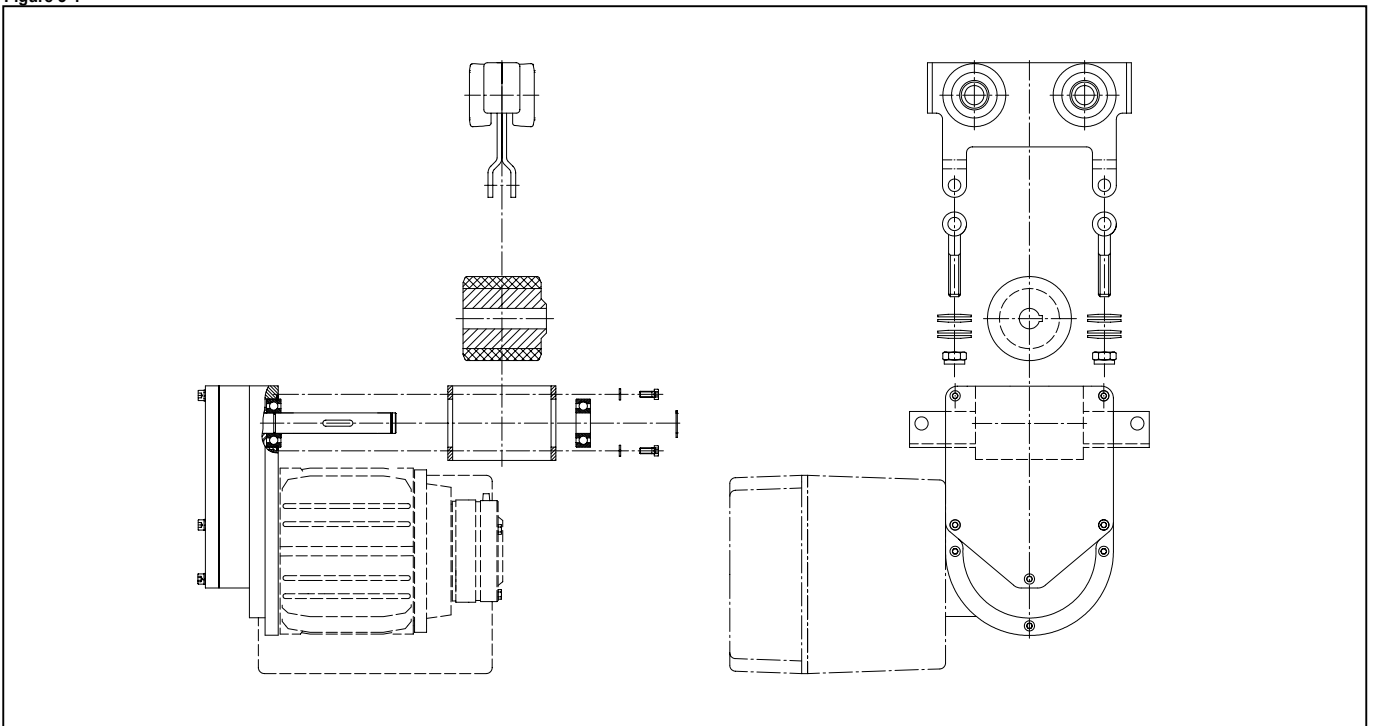

Figure 3-1



Contactor control
Schützensteuerung
Commande par contacteurs

2 speed with emergency stop
2 Geschwindigkeiten mit Not-Aus
2 vitesses avec marche-arrêt

3 Ph

9243.9566.3

